



STEVAL-ISA006V1

6W non-isolated fly-back topology power supply with VIPer12AS

Data Brief

Features

- Switch mode general purpose power supply
- Input: 90 to 264Vac @ 50/60Hz
- Main Output (regulated): 5V, 500mA @ 50/60Hz
- Second output: 15V, 200mA
- Output power (pick): 5.5W

Description

This reference design is an auxiliary power supply based on the VIPer12AS monolithic device and can be used to produce multiple non isolated positive or negative voltage outputs.

This solution is based on an offline discontinuous current mode fly-back converter without isolation between input and output. The fly-back topology allows the exploitation of the VIPer12AS current capability when compared with the buck converter based power supply. To ensure power supply low cost, the isolation between input and output is not provided. This greatly simplifies the transformer design and production. The VIPer12AS incorporates the PWM controller with a 60kHz internal oscillator and the vertical Power MOSFET switch in a SO-8 package. The presented power supply has four variants. All the variants have been incorporated in the presented reference board through different assembly options.

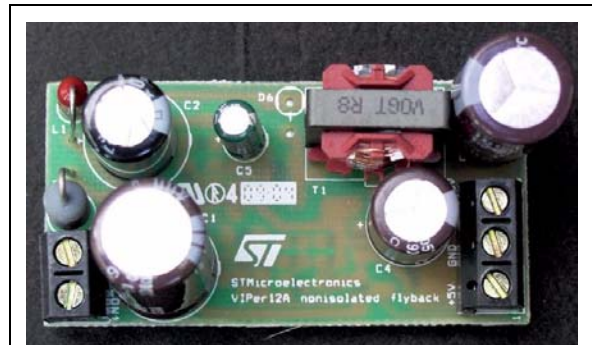

STEVAL-ISA006V1

ST Components

- VIPer12AS off-line SMPS primary
- STPR120A diode, fast recovery $t_{rr} = 25ns$ 200V 1A SMA
- STPS1L40A diode, schottky, 40V 1A,
- TS2431ILT programmable shunt voltage reference

1 General circuit description

The output of the converter is not isolated from the input. For this reason the reference ground is common for an input and output connection terminal. The input capacitor C1 is charged from the mains by single rectification consisting of diodes D1 and D2. Two diodes in series are used for EMI reasons to sustain burst pulses of 2kV. Capacitor C1 together with capacitor C2 and inductor L1 form an EMI filter. The DC voltage at C2 is then applied to the transformer primary winding through the internal Power MOSFET switch of VIPer12 during the switching period ON time. The snubber circuit consisting of resistor R3 and capacitor C6 reduces the voltage spike across the transformer primary winding due to the parasitic leakage inductance. Through rectifiers D4 and D5 and through smoothing capacitors C3 and C4, the power supply provides two outputs from two transformer windings. The VIPer12AS is supplied by a 15V output voltage through transistor Q2 and diode D7. The voltage feedback loop senses the 5V output through resistor divider R5, R7. The control IC U2 compares the resistor divider output voltage to the internal reference voltage of 2.5V and changes the cathode voltage accordingly to keep 5V output stable. The FB pin current will decrease the peak primary current to reduce the power delivered to the outputs.

2 Board schematic

Figure 1. Scheme

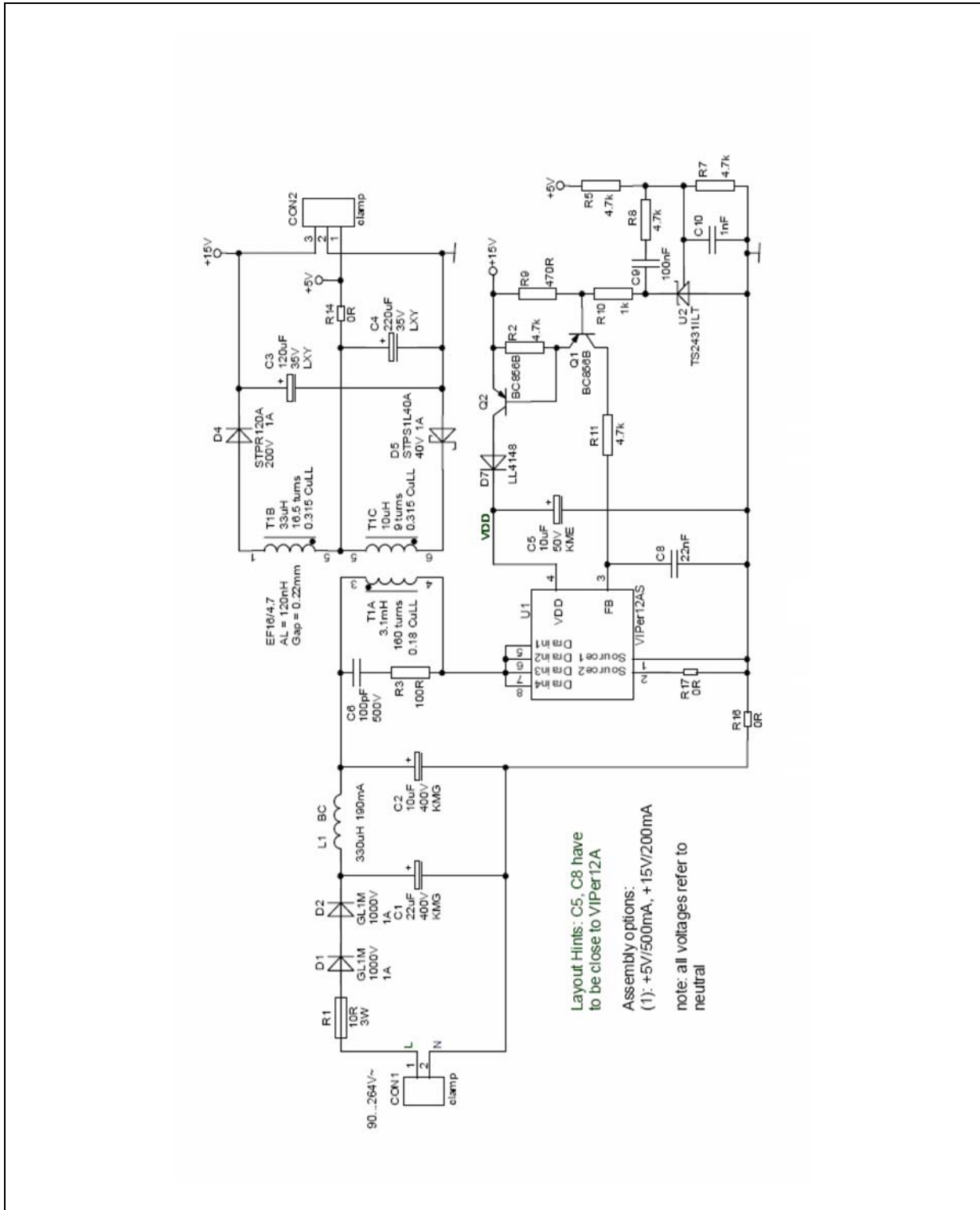

3 Revision history

Table 1. Revision history

Date	Revision	Changes
20-Jul-2007	1	Initial release.

Please Read Carefully:

Information in this document is provided solely in connection with ST products. STMicroelectronics NV and its subsidiaries ("ST") reserve the right to make changes, corrections, modifications or improvements, to this document, and the products and services described herein at any time, without notice.

All ST products are sold pursuant to ST's terms and conditions of sale.

Purchasers are solely responsible for the choice, selection and use of the ST products and services described herein, and ST assumes no liability whatsoever relating to the choice, selection or use of the ST products and services described herein.

No license, express or implied, by estoppel or otherwise, to any intellectual property rights is granted under this document. If any part of this document refers to any third party products or services it shall not be deemed a license grant by ST for the use of such third party products or services, or any intellectual property contained therein or considered as a warranty covering the use in any manner whatsoever of such third party products or services or any intellectual property contained therein.

UNLESS OTHERWISE SET FORTH IN ST'S TERMS AND CONDITIONS OF SALE ST DISCLAIMS ANY EXPRESS OR IMPLIED WARRANTY WITH RESPECT TO THE USE AND/OR SALE OF ST PRODUCTS INCLUDING WITHOUT LIMITATION IMPLIED WARRANTIES OF MERCHANTABILITY, FITNESS FOR A PARTICULAR PURPOSE (AND THEIR EQUIVALENTS UNDER THE LAWS OF ANY JURISDICTION), OR INFRINGEMENT OF ANY PATENT, COPYRIGHT OR OTHER INTELLECTUAL PROPERTY RIGHT.

UNLESS EXPRESSLY APPROVED IN WRITING BY AN AUTHORIZED ST REPRESENTATIVE, ST PRODUCTS ARE NOT RECOMMENDED, AUTHORIZED OR WARRANTED FOR USE IN MILITARY, AIR CRAFT, SPACE, LIFE SAVING, OR LIFE SUSTAINING APPLICATIONS, NOR IN PRODUCTS OR SYSTEMS WHERE FAILURE OR MALFUNCTION MAY RESULT IN PERSONAL INJURY, DEATH, OR SEVERE PROPERTY OR ENVIRONMENTAL DAMAGE. ST PRODUCTS WHICH ARE NOT SPECIFIED AS "AUTOMOTIVE GRADE" MAY ONLY BE USED IN AUTOMOTIVE APPLICATIONS AT USER'S OWN RISK.

Resale of ST products with provisions different from the statements and/or technical features set forth in this document shall immediately void any warranty granted by ST for the ST product or service described herein and shall not create or extend in any manner whatsoever, any liability of ST.

ST and the ST logo are trademarks or registered trademarks of ST in various countries.

Information in this document supersedes and replaces all information previously supplied.

The ST logo is a registered trademark of STMicroelectronics. All other names are the property of their respective owners.

© 2007 STMicroelectronics - All rights reserved

STMicroelectronics group of companies

Australia - Belgium - Brazil - Canada - China - Czech Republic - Finland - France - Germany - Hong Kong - India - Israel - Italy - Japan - Malaysia - Malta - Morocco - Singapore - Spain - Sweden - Switzerland - United Kingdom - United States of America

www.st.com

